

# DJSF1352-RN

## Technical parameter

Technical parameters		Indicators		
Input	Nominal value	Voltage input range	Current input	
		DC 0-1000V See the physical wiring diagram	Shunt 0-75mV Hall sensor 0-20mA a 4-20mA a 0-5V 0-10V and so on.	
	Overload	1.2 times rated (continuous); 2 times rated/1 second;		
	Power consumption	9 R O W D J H " 9 \$ F X U U H Q W " 9 \$		
Accuracy class		Class 1		
Function	Display	8-bit segment LCD screen (LCD)		
	Communication Interface	RS485, infrared		
	Communication protocol	Modbus-RTU DL/T 645-2007		
	Switch	Switch output	2 Relay outputs, 2A/30VDC or 2A/250VAC	
		Switch input	2 dry contact inputs	
Pulse output	A second pulse output, a energy pulse output See the SYS->PLUS display in the meter menu settings. For example: The meter displays 100, which is 100imp/kWH			
Power Supply	Voltage range	AC/DC 85-265V or DC24V(±10%) or DC48V(±10%)		
	Power consumption	" :		
Power frequency withstand voltage		Power supply // Voltage input // Current input // Relay output and switch input // Communication interface // Pulse output 3kV/1min Power supply // Relay output // Voltage input // Current input 3kV/1min Pulse output // Communication interface // Switch input 2kV/1min		
Insulation resistance		• 0		
Average barrier-free working hours		• K		
Environment	Temperature	Normal operating temperature: -25 °C ~ +65 °C;		
		Limit working temperature: -40 °C ~ +70 °C;		
		Storage temperature: -40 ¥ j +80 ¥		
Humidity	" 5+ Q R F R Q G H Q V D W L R Q Q R F R U R V			
Altitude	" P			

## General

DJSF1352-RN rail-mounted DC power meter with double DC input channels, designed for telecommunications base stations, DC charging piles, solar photovoltaic and other applications, this series of meters can measure the voltage, current, power and forward and reverse energy and so on in the DC system. The actual use of the site, you can measure the total power, but also measure the energy within a specified period of time. The test results can be used for local display, but also with industrial control equipment, computers to form a measurement and control system.

The meter can have infrared communication interface and RS-485 communication interface, and supports Modbus-RTU protocol and DLT645-97 (07) protocol at the same time. The meter can have relay alarm output and digital input function; You can set the ratio, alarm, and communication through the meter panel keys according to different requirements. The meter can have event recording of switch (Modbus protocol), programming and event setting records (645 protocol), instantaneous and timing freeze function of data (645 protocol), maximum and minimum value recording function of voltage and current power.

## Model Description

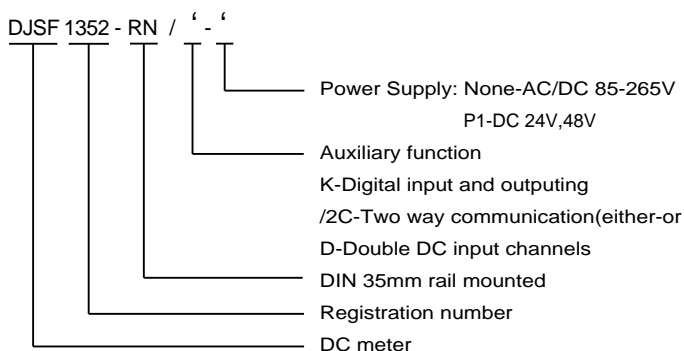

### 3 Pulse constant:

Maximum power	999.9W	10000	imp/kWh
	9.999kW	1000	imp/kWh
	99.99kW	100	imp/kWh
	999.9kW	10	imp/kWh
	9999kW	1	imp/kWh

Maximum power = rated voltage \* voltage ratio \* current ratio \* 1.2

## Dimension

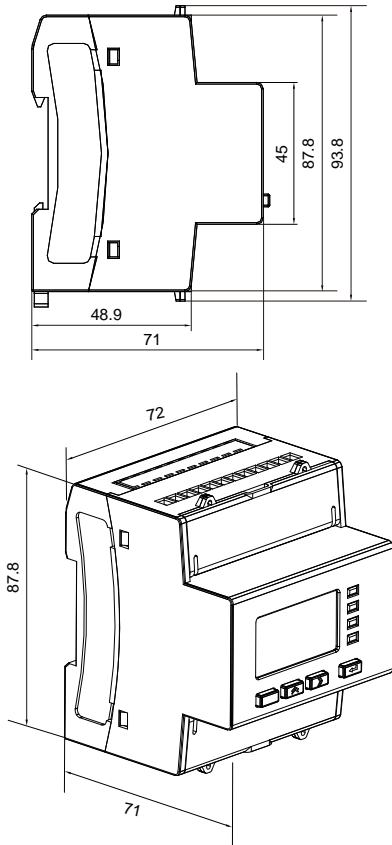

## Wiring

The meter is designed by standard DIN35mm rail mounted.

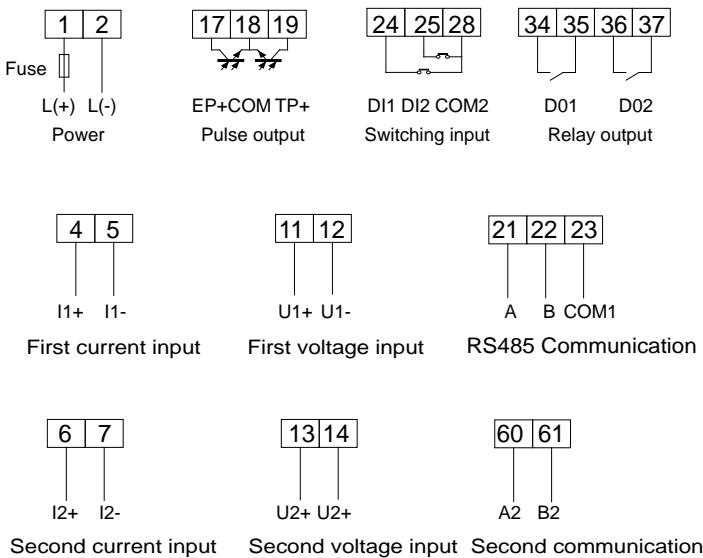

Note: The second DC input channel and DI and DO functions are optional.

When the current input mode is current shunt input:

## 3 Three-wire connection

Current shunt connected to the positive

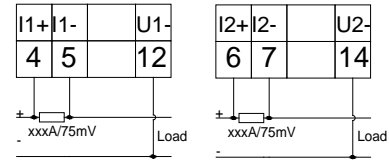

First DC input channel

Current shunt connected to the negative

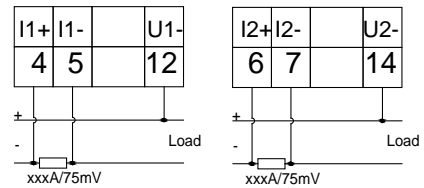

Second DC input channel

## 3 Four-wire connection

Current shunt connected to the positive

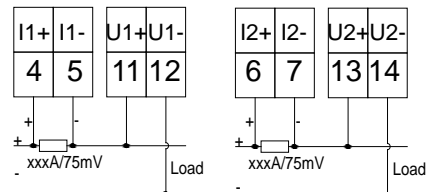

Current shunt connected to the negative

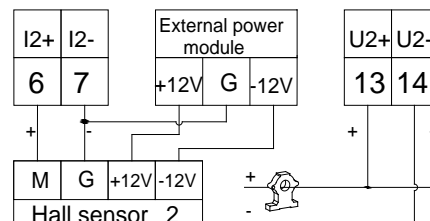
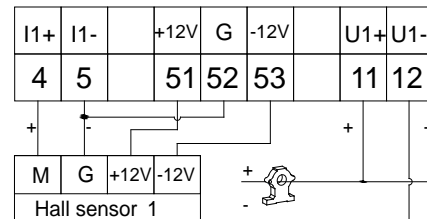
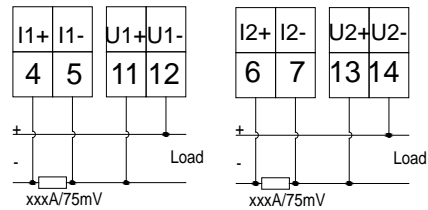





Note: 1. When current shunt is connected to the negative, set the  option to on in the meter menu, see section 6 menu programming interface for details.

2. When the two current inputs are input by the Hall current sensor, the power supply of the second Hall current sensor cannot be used with the built-in power supply of the meter, and the power module needs to be externally connected.

3. When the current is input by the shunt, the voltage value measured by the four-wire method has an error of about one thousandth.

4. It is recommended to use a 0.75mm<sup>2</sup> or 1mm<sup>2</sup> shielded twisted pair for the current signal line, and the shield layer needs to be connected to the ground.

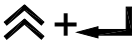
## Operation

<p>SET button</p>	<p>In the measurement mode, press this key to enter the programming mode. The meter prompts you to enter the password PASS. After you enter the correct password, you can program the instrument; in the programming mode, it returns to the previous menu</p>
<p></p>	<p>In the measurement mode, it is used to switch the display item and view the electrical parameters, see the display menu for details; In the programming mode, it is used to switch the menu of the same level or reduce the number of ones place.</p>
<p></p>	<p>In the measurement mode, it is used to switch the display item and view the electrical parameters, see the display menu for details; In the programming mode, it is used to switch the menu of the same level or add the number of ones place.</p>
<p></p>	<p>In the programming mode, it is used to confirm the selection of menu items and modify the parameters.</p>
<p></p>	<p>In the programming mode, this key combination is used to reduce the number of hundreds place.</p>
<p></p>	<p>In the programming mode, this key combination is used to add the number of hundreds place.</p>